

PMC-D721MD

Digital Multifunction Meter

User Manual

Version: V1.0

June 25, 2018



This manual may not be reproduced in whole or in part by any means without the express written permission from CET.

The information contained in this manual is believed to be accurate at the time of publication; however, CET assumes no responsibility for any errors which may appear here and reserves the right to make changes without notice. Please consult CET or your local representative for the latest product specifications.



DANGER

This symbol indicates the presence of danger that may result in severe injury or death and permanent equipment damage if proper precautions are not taken during the installation, operation or maintenance of the device.



CAUTION

This symbol indicates the potential of personal injury or equipment damage if proper precautions are not taken during the installation, operation or maintenance of the device.



Failure to observe the following instructions may result in severe injury or death and/or equipment damage.

- Installation, operation and maintenance of the meter should only be performed by qualified, competent personnel that have the appropriate training and experience with high voltage and current devices. The meter must be installed in accordance with all local and national electrical codes.
- Ensure that all incoming AC power and other power sources are turned OFF before performing any work on the meter.
- Before connecting the meter to the power source, check the label on top of the meter to ensure that it is equipped with the appropriate power supply, and the correct voltage and current input specifications for your application.
- During normal operation of the meter, hazardous voltages are present on its terminal strips and throughout the connected potential transformers (PT) and current transformers (CT). PT and CT secondary circuits are capable of generating lethal voltages and currents with their primary circuits energized. Follow standard safety precautions while performing any installation or service work (i.e. removing PT fuses, shorting CT secondaries...etc).
- Do not use the meter for primary protection functions where failure of the device can cause fire, injury or death. The meter should only be used for shadow protection if needed.
- Under no circumstances should the meter be connected to a power source if it is damaged.
- To prevent potential fire or shock hazard, do not expose the meter to rain or moisture.
- Setup procedures must be performed only by qualified personnel familiar with the instrument and its associated electrical equipment.
- DO NOT open the instrument under any circumstances.

Limited warranty

- CET offers the customer a minimum of 12-month functional warranty on the meter for faulty parts or workmanship from the date of dispatch from the distributor. This warranty is on a return to factory for repair basis.
- CET does not accept liability for any damage caused by meter malfunctions. CET accepts no responsibility for the suitability of the meter to the application for which it was purchased.
- Failure to install, set up or operate the meter according to the instructions herein will void the warranty.
- Only CET's duly authorized representative may open your meter. The unit should only be opened in a fully anti-static environment. Failure to do so may damage the electronic components and will void the warranty.

Table of Contents

Chapter 1 Introduction	7
1.1 Overview	7
1.2 Features.....	7
1.3 Getting more information	8
Chapter 2 Installation	9
2.1 Appearance	9
2.2 Unit Dimensions	10
2.3 Mounting.....	10
2.4 Input Wiring	11
2.5 Communications Wiring.....	11
2.6 Digital Input Wiring	11
2.7 Pulse Output Wiring	12
2.8 Power Supply Wiring	12
Chapter 3 Front Panel.....	13
3.1 Display	13
3.1.1 LCD Testing.....	13
3.1.2 LCD Display Areas.....	13
3.2 Using the Front Panel Buttons.....	15
3.3 LED Pulse Outputs	15
3.4 Display Screen Types	15
3.5 Setup Configuration via the Front Panel	15
3.5.1 Making Setup Changes.....	16
3.5.2 Setup Menu	16
3.5.3 Configuration	17
Chapter 4 Applications	18
4.1 Digital Inputs	18
4.2 Pulse Outputs	18
4.3 Basic Measurement.....	18
4.4 SOE	18
Chapter 5 Modbus Register Map.....	19
5.1 Basic Measurements	19
5.2 SOE Log.....	19
5.3 Device Setup.....	21
5.3.1 Basic Setup Parameters.....	21
5.3.2 I/O Setup Parameters.....	21
5.3.3 Energy Pulse Setup Parameter	21
5.3.4 Communication Setup Parameters	21
5.4 Time.....	21
5.5 Clear Control	22
5.6 Meter Information.....	22
Appendix A Technical Specifications.....	24

Appendix B Standards Compliance..... 25
Appendix C Ordering Guide 26
Contact us..... 27

Chapter 1 Introduction

This manual explains how to use the PMC-D721MD DC Multifunction Meter. Throughout the manual the term “meter” generally refers to all models. Differences between the models are indicated with the appropriate model number.

This chapter provides an overview of the PMC-D721MD meter and summarizes many of its key features.

1.1 Overview

The PMC-D721MD DC Multifunction Meter is CET’s latest offer for the low-cost DC metering market. Housed in an industry standard DIN form factor measuring 72mmx72mmx71.8mm, it is perfectly suited for industrial, commercial and utility DC metering applications. The PMC-D721MD complies with Class 0.5S kWh Accuracy Standard and features quality construction, multifunction measurements and a bright, easy to read LCD display. The PMC-D721MD comes standard with two front panel LED indicators for Energy Pulsing and Communication. It optionally provides two Digital Inputs for Status Monitoring and two Solid State Pulse Outputs for kWh Energy Pulsing applications. The standard SOE Log records meter events such as power-off, setup changes and DI operations in 1ms resolution. With the standard RS485 port and Modbus protocol support, the PMC-D721MD becomes a vital component of an intelligent, multifunction monitoring solution for any DC Power and Energy Management systems.

You can setup the meter through its front panel or via our free PMC Setup software. The meter is also supported by our PecStar® iEMS Integrated Energy Management System.

Following is a list of typical applications for the PMC- D721MD:

- DC Inverter, DC Panel Metering and DC Charging Station
- Industrial and commercial DC metering
- DC Distribution Monitoring

Contact CET Technical Support should you require further assistance with your application.

1.2 Features

Ease of use

- Large, backlit LCD display with wide viewing angle
- Intuitive user interface
- LED indicators for Energy Pulsing and Communication activities
- Password-protected setup via front panel or free PMC Setup software
- Easy installation with mounting clips, no tools required

Measurements

- Voltage, Current and kW
- Bi-directional kWh measurements

SOE Log

- 32 events time-stamped to ± 1 ms resolution
- Record all setup and Digital Input status changes

Inputs and Outputs

- 2xFront Panel LED indicators for Energy Pulsing and Communication
- Optional 2xDigital Inputs for Status Monitoring
- Optional 2xSolid State Relay for kWh Imp and kWh Exp Pulse Output.

Communications

- Standard RS-485 port with Modbus RTU support at 1200 to 19,200 bps equipped

System Integration

- Supported by CET's PecStar® iEMS and PMC Setup
- Easy integration into other Automation, SCADA or BMS systems via Modbus RTU

1.3 Getting more information

Additional information is available from CET via the following sources:

- Visit www.cet-global.com
- Contact your local representative
- Contact CET directly via email or telephone

Chapter 2 Installation



Caution

Installation of the PMC-D721MD should only be performed by qualified, competent personnel that have the appropriate training and experience with high voltage and current devices. The meter must be installed in accordance with all local and national electrical codes.

During the operation of the meter, hazardous voltages are present at the input terminals. Failure to observe precautions can result in serious or even fatal injury and equipment damage.

2.1 Appearance



Figure 2-1 Appearance

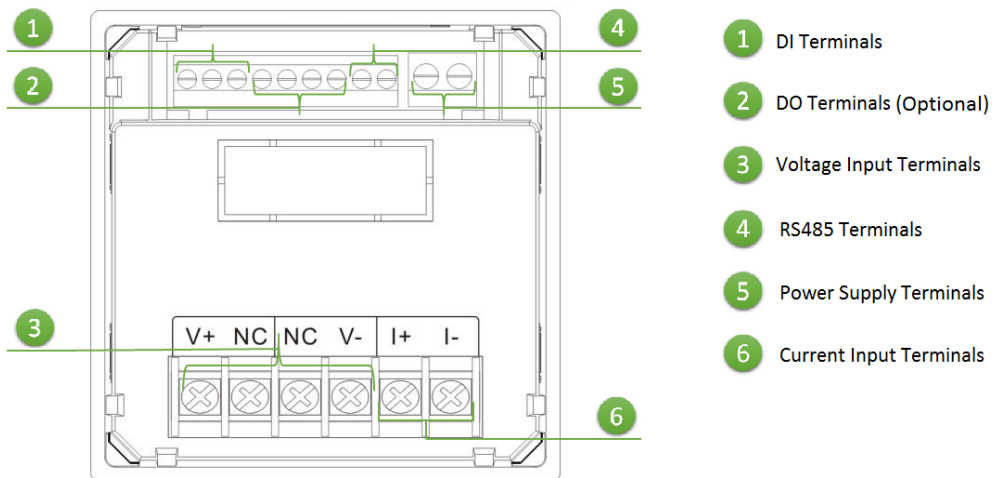

Figure 2-2 Rear Panel (2DIs + 2DOs)

2.2 Unit Dimensions

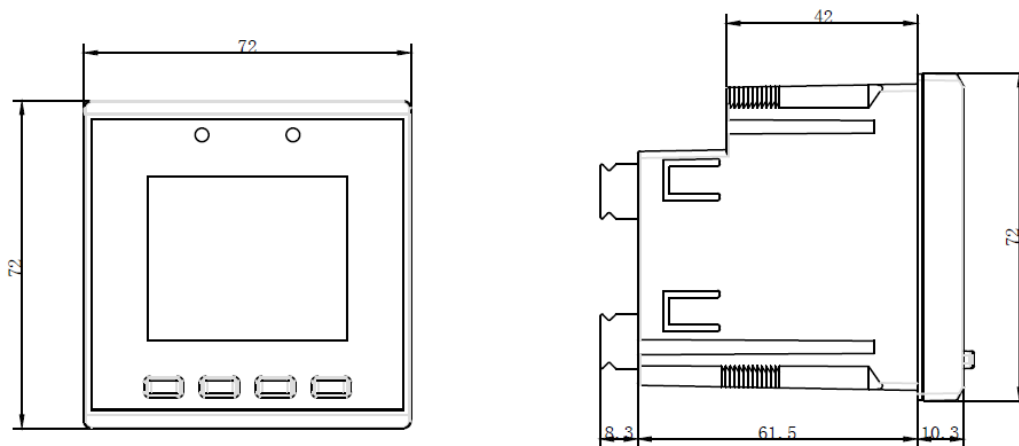

Figure 2-3 Dimension

2.3 Mounting

The PMC-D721MD meter should be installed in a dry environment with no dust and kept away from heat, radiation and electrical noise source.

Installation steps:

- Remove the installation clips from the meter
- Fit the meter through a 68mmx68mm cutout as shown in Figure 2-4
- Re-install the installation clips and push the clips tightly against the panel to secure the meter

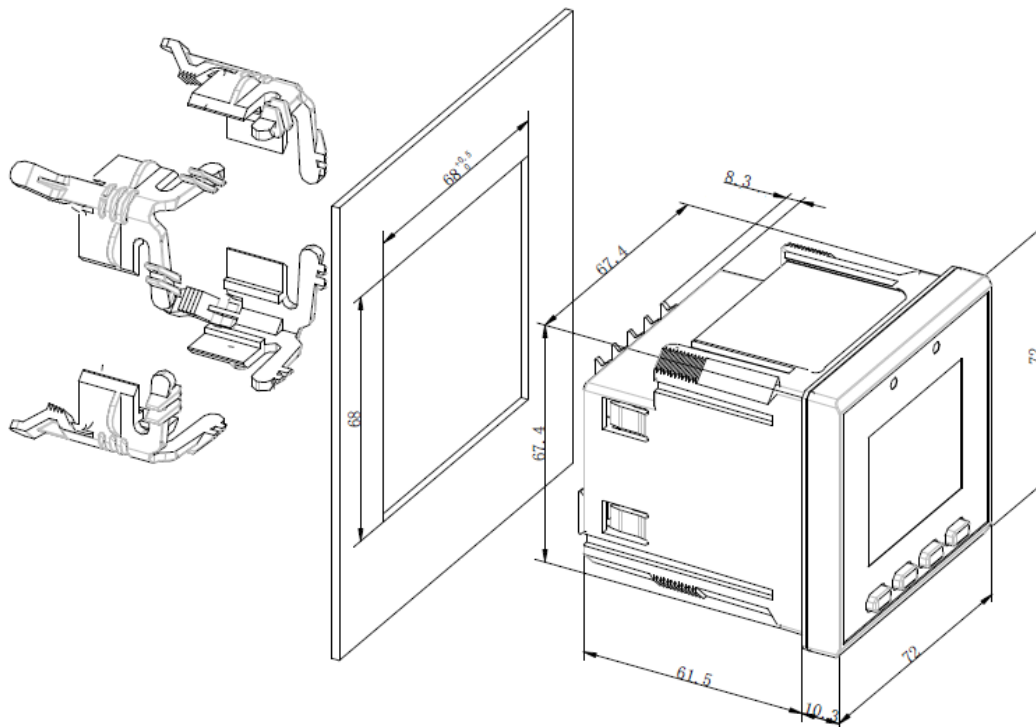

Figure 2-4 Panel Cutout

2.4 Input Wiring

Please consult the serial number label to ensure that the voltage and current input is less than or equal to the meter's input specification.

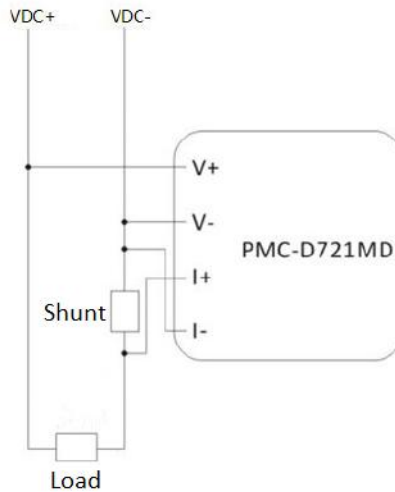

Figure 2-5 Input Connections

2.5 Communications Wiring

The following figure illustrates the RS485 communications connections on the PMC-D721MD:

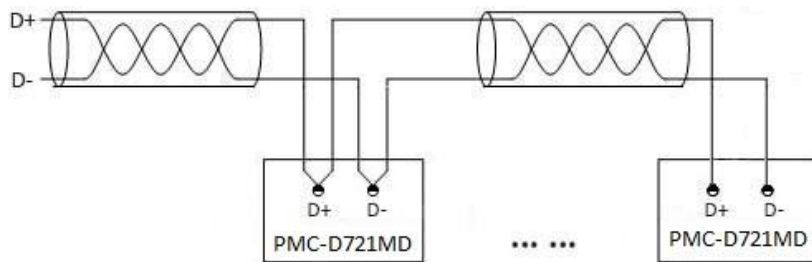

Figure 2-6 Communications Connections

The PMC-D721MD provides one RS485 port and supports the Modbus RTU protocol. Up to 32 devices can be connected on a RS485 bus. The overall length of the RS485 cable connecting all devices should not exceed 1200m.

If the master station does not have a RS485 communications port, a RS232/RS485 or USB/RS485 converter with optically isolated output and surge protection should be used.

2.6 Digital Input Wiring

The following figure illustrates the Digital Input connections on the PMC-D721MD:

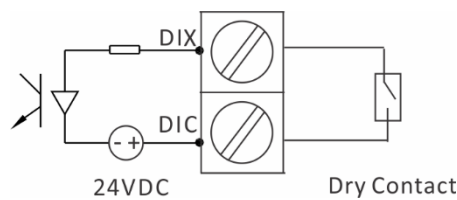

Figure 2-7 DI Connections

2.7 Pulse Output Wiring

The following figure illustrates the Pulse Output connections on the PMC-D721MD:

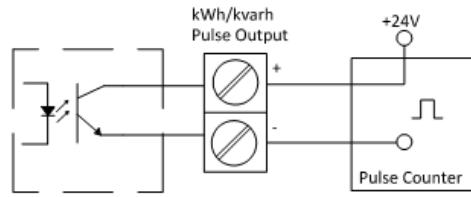

Figure 2-8 Pulse Output Connections

2.8 Power Supply Wiring

For AC supply, connect the live wire to the L/+ terminal and the neutral wire to the N/- terminal.

For DC supply, connect the positive wire to the L/+ terminal and the negative wire to the N/- terminal.

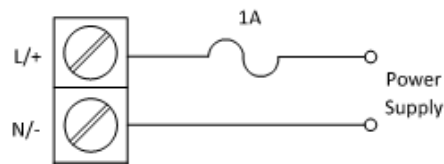

Figure 2-9 Power Supply Connections

Chapter 3 Front Panel

The PMC-D721MD meter has a large, bright, backlit LCD display and four buttons for data display and meter configuration. This chapter introduces the front panel operations.



Figure 3-1 Front Panel

3.1 Display

3.1.1 LCD Testing

Pressing both the <Phase> and the <Energy> buttons simultaneously for 2 seconds enters the LCD Testing mode. All LCD segments are illuminated during testing. The LCD will return to its normal display mode when any button is pressed.

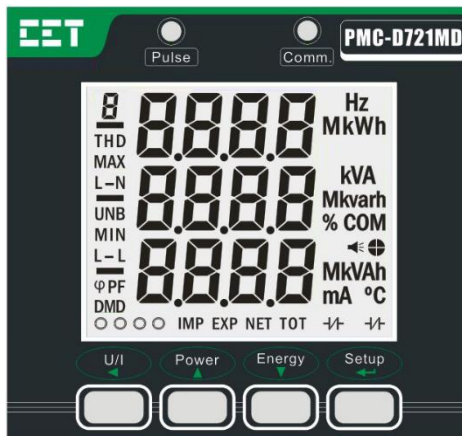

Figure 3-2 Full LED/LCD Display

3.1.2 LCD Display Areas

This section provides a description of the LCD display areas. The PMC-D721MD with LCD display can generally be divided into 4 areas:

A: Measurement symbols for Voltage and Current. Other symbols such as THD, Unbalance, PF, Voltage Phase Angle, Current Phase Angle and Demand are reserved.

B: Measurement values

C: Measurement Units of kW and kWh. Other symbols such as Comm. Indicator, Hz, kvar/kvarh, kVA/kVAh, PF Quadrant status symbols, mA and °C are reserved.

D: DI Status and kWh Imp/Exp indicators. DO Status and kWh Net/Total indicators are reserved.

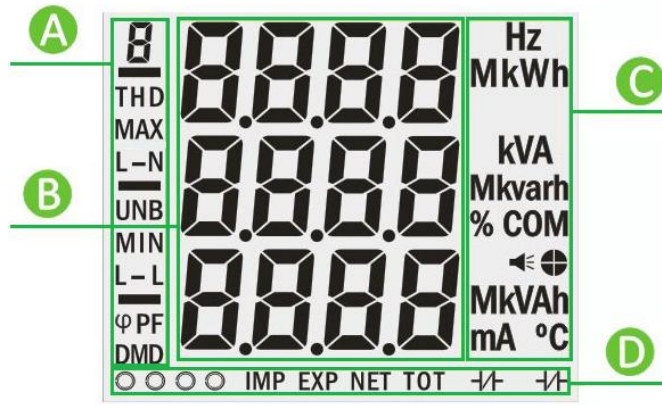

Figure 3-3 LCD Display

The following table shows the special LCD display symbols:

NO.	Label	Description			
A		Voltage		Current	
	THD MAX L-N UNB MIN L-L φ PF DMD	Reserved			
C	MkWh	Measurement Units of Power (kW) and Energy (kWh).			
	Hz kVA Mkvarh % COM ⚡ MkVAh mA °C	Reserved			
D	● IMP EXP	○ DI Open	● DI Close	IMP Import	EXP Export
	NET TOT	Reserved			

Table 3-1 LCD Display Symbols

3.2 Using the Front Panel Buttons

The button definitions under **Data Display Mode** and **Setup Configuration Mode** are explained in the following table. The default password is 0.

Buttons	Data Display Mode	Setup Configuration Mode
<U/I>	Pressing <U/I> views the Voltage and Current measurements.	<ul style="list-style-type: none"> Once a parameter is selected, pressing this button moves the cursor to the left by one position if the parameter being changed is a numeric value.
<Power>	Pressing <Power> views the kW measurements.	<ul style="list-style-type: none"> Before a parameter is selected for modification, pressing this button advances to the next parameter in the menu. If a parameter is already selected, pressing this button increments a numeric value or advances to the next value in the selection list.
<Energy>	Pressing <Energy> views kWh Import and kWh Export parameters.	<ul style="list-style-type: none"> Before a parameter is selected for modification, pressing this button goes back to the last parameter in the menu. If a parameter is already selected, pressing this button decrements a numeric value or goes back to the last value in the selection list.
<Setup>	This button is ignored.	<ul style="list-style-type: none"> Pressing this button for more than two seconds toggles between Data Display mode and Setup Configuration mode. Once inside the Setup Configuration mode and at the main menu, pressing this button selects a sub-menu or a parameter for modification. After changing the parameter, pressing this button again saves the new setting into memory.

Table 3-2 Buttons Description

3.3 LED Pulse Outputs

The PMC-D721MD comes standard with one LED indicator for Energy Pulse Output which can be used for kWh energy pulsing if the **EN PULSE** is enabled (see **Section 4.2 LED Pulse Outputs** for more information) and a second LED indicator for Communication Status.

3.4 Display Screen Types

The front panel provides two display modes: **Data Display** and **Setup Configuration**. There are four buttons on the front panel: <U/I>, <Power>, <Energy> and <Setup>. The <Setup> button is only used when configuring the meter.

The following table illustrates the display screens for the PMC-D721MD model.

Press button	Display screens	First row	Second row	Third row
<U/I>	Display 1 (default)	-	Voltage	Current
<Power>	Display 1	-	Power	-
<Energy>	Display 1	kWh Import		
	Display 2	kWh Export		

Table 3-3 PMC-D721MD Data Display Screens

3.5 Setup Configuration via the Front Panel

Pressing the <Setup> button for more than 2 seconds enters the **Setup Configuration** mode where the setup parameters can be changed. Upon completion, pressing the <Setup> button for more than 2 seconds returns to the **Data Display** mode.

3.5.1 Making Setup Changes

1) Entering the Password:

- Press the <Setup> button for more than 2 seconds to access **Setup Configuration** mode.
- Press the <Energy> button to advance to the Password page.
- A correct password must be entered before changes are allowed. The factory default password is zero. Press the <Setup> button to select the parameter for modification. Use the <U/I>, <Power> and <Energy> buttons to enter the correct password.

2) Selecting a parameter to change:

- Use the < Power > and <Energy> button to scroll to the desired parameter.
- Press the <Setup> button to select the parameter. Once selected, the parameter value will blink.

3) Changing and saving a parameter:

- Use the <U/I>, <Power> and <Energy> buttons to make modification to the selected parameter.
- After modification, press the <Setup> button to save the new value into memory.
- If necessary, pressing the <U/I> button from inside a sub-menu to return to the main menu.

4) Returning to Data Display mode:

- Pressing the <Setup> button for more than 2 seconds to return to the default display screen.

3.5.2 Setup Menu

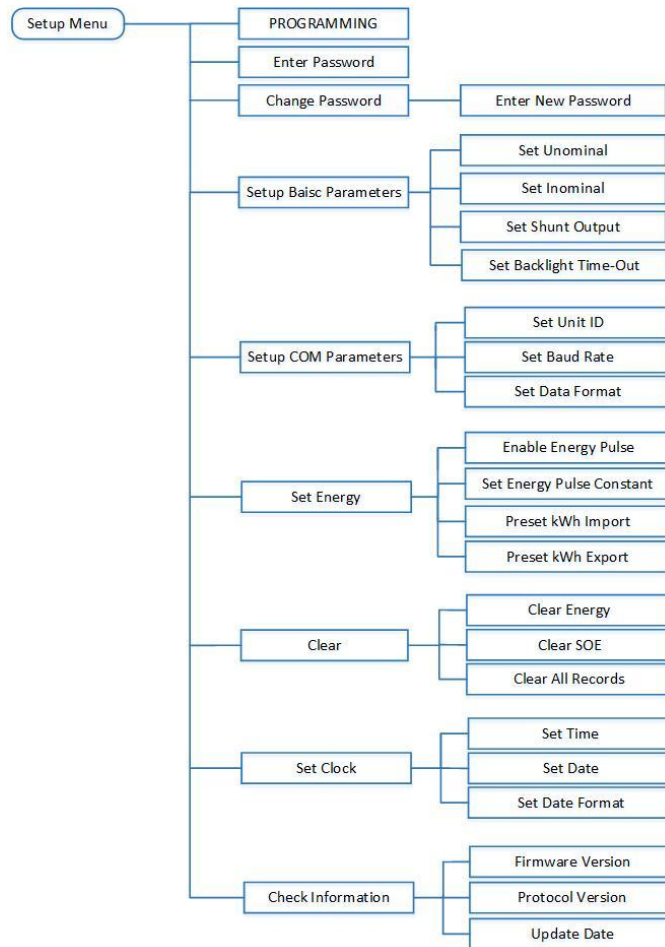

Figure 3-3 Setup Menu

3.5.3 Configuration

The Setup Configuration mode provides access to the following setup parameters:

Label		Parameters	Description	Range	Default
Main	Sub				
PROG		Programming	Setup Configuration Mode	/	/
PASS		Password	Enter Password	0 to 9999	"0"
PASS SET		Change Password			
	NEW PASS	New Password	Change Password	0000 to 9999	"0"
SYS SET		Setup System Parameters			
	Un	Unominal	Set nominal Voltage	1 to 1000V	750
	I E	Inominal	Set nominal Current	1 to 10000A	100
	SH	Shunt Output	Set Shunt Nom. Output	1 to 100mV	75
	BLTO	Backlight Time-Out	Set Backlight Time-out	0 to 60 mins	3
COM SET		Setup Comm. Parameters			
	ID	Meter Address	Set Modbus Unit ID	1-247	100
	BAUD	Baud rate	Set Data rate in bits per second	1200/2400/4800/9600/19200bps	9600
	CFG	Data Format	Set Comm. Port Configuration	8N2/8O1/8E1/8N1/8O2/8E2	8E1
ENGY SET		Setup Energy Outputs Parameters and Preset kWh Import/Export.			
	ENGY PULS	Energy Pulsing	Enable Energy Pulsing	YES/NO	YES
	ENGY CNST	Pulse Constant	Pulse Constant	25/100/400/1000/3200 imp/kWh	100
	kWh Import	kWh Import	Preset kWh Import	0 to 99,999,999.9	0
	kWh Export	kWh Export	Preset kWh Export	0 to 99,999,999.9	0
IO SET ¹		Specifies the minimum duration the DI must remain in the Active or Inactive state before a state change is considered to be valid.			
	DI1	DI1 Debounce	DI1 Debounce	1 to 9999ms	20
	DI2	DI2 Debounce	DI2 Debounce	1 to 9999ms	20
CLR					
	ENEY	Clear Energy	Clear Energy Registers	YES/NO	NO
	SOE CLR	Clear SOE	Clear SOE Log	YES/NO	NO
	ALL CLR	Clear All Records	Clear Energy Registers and SOE Log	YES/NO	NO
TM SET		Setup Date and Clock			
	DATE	Date	Enter the Current Date	YYYY-MM-DD	/
	CLK	Clock	Enter the Current Time	HH:MM:SS	/
INFO		Check meter information			
	FW	Firmware Version	Firmware Version	e.g. 1.00.00 means V1.00.00	/
	PROT VER	Protocol Version	Protocol Version	e.g. 1.0 means V1.0	/
	UPDT	Update Date	Firmware Update Date	e.g. 20130603	/

Table 3-4 Setup Parameters

Notes:

- 1) The I/O setup parameters are only displayed when the PMC-D721MD is equipped with this option.

Chapter 4 Applications

4.1 Digital Inputs

The PMC-D721MD comes optionally with two self-excited Digital Inputs that are internally wetted at 24 VDC. Digital Inputs are typically used for monitoring external status which can help prevent equipment damage, improve maintenance and track security breaches. The real-time statuses of the Digital Inputs are available on the front panel LCD Display as well as through communications. Changes in Digital Input status are stored as events in the SOE Log in 1 ms resolution.

4.2 Pulse Outputs

The PMC-D721MD comes standard with one front panel LED Pulse Output for Energy Pulsing and can be equipped with two optional Solid Relay Output for kWh Imp and kWh Exp energy pulsing where DO Energy Pulse Outputs are typically used for accuracy testing. Energy pulsing can be enabled from the front panel through the **ENGY PULS** setup parameter. The pulse constant can be configured as 25/100/400/1000/3200 imp/kWh through the **ENGY CNST** setup parameter.

4.3 Basic Measurement

The PMC-D721MD provides following basic measurements which are available through the LCD display or communication:

- Voltage, Current and kW
- kWh Import and kWh Export

4.4 SOE

The PMC-D721MD can store up to 32 events such as Power-On, Power-Off, Digital Input status changes and setup changes in its non-volatile memory. Each event record includes the event classification, its relevant parameter values and a timestamp in 1ms resolution.

All event records can be retrieved via communications. If there are more than 32 events, the newest event will replace the oldest event on a First-In-First-Out basis. The SOE Log can be reset from the front panel or via communications.

Chapter 5 Modbus Register Map

This chapter provides a complete description of the Modbus register map (**Protocol Versions 1.0** and above) for the PMC-D721MD Digital Multifunction Meter to facilitate the development of 3rd party communications driver for accessing information on the PMC-D721MD.

The PMC-D721MD supports the following Modbus functions:

- 1) Read Holding Registers (Function Code 0x03)
- 2) Force Single Coil (Function Code 0x05)
- 3) Preset Multiple Registers (Function Code 0x10)

The following table provides a description of the different data formats used for the Modbus registers.

The PMC-D721MD uses the Big Endian byte ordering system.

Format	Description
UINT16/INT16	Unsigned/Signed 16-bit Integer
UINT32/INT32	Unsigned/Signed 32-bit Integer
Float	IEEE 754 32-bit Single Precision Floating Point Number

For a complete Modbus Protocol Specification, please visit www.modbus.org.

5.1 Basic Measurements

Register	Property	Description	Format	Scale	Unit
0000	RO	U	Float	x1	V
0002	RO	I	Float	x1	A
0004	RO	kW	Float	x1	W
0006-0029	RO	Reserved			
0030	RO	DI Status	UINT16		
0031	RO	Reserved			
0032	RO	SOE Pointer	UINT32		
0034-0039	RO	Reserved			
0040	RO	kWh Import	INT32	x0.01	kWh
0042	RO	kWh Export	INT32	x0.01	kWh

Table 5-1 Basic Measurements

Notes:

- 1) For the **DI Status** register, the bit values of B0 and B1 represent the states of DI1 and DI2, respectively, with "1" meaning active (closed) and "0" meaning inactive (open).
- 2) The range of the **SOE Pointer** is between 0 and 0xFFFFFFFF and it is incremented by one for every new log generated and will roll over to 0 if its current value is 0xFFFFFFFF. A value of zero indicates that the SOE does not contain any Log. If a **SOE CLR** is performed from the front panel or via communications, the **SOE Pointer** will be reset to zero and then immediately incremented by one with a new "Setup Changes via Front Panel" or "Setup Changes via Communications" event. Therefore, any 3rd party software should assume that a **SOE CLR E** action has been performed if it sees the **SOE Pointer** rolling over to one or to a value that is smaller than its own pointer. In this case, the new **SOE Pointer** also indicates the number of events in the SOE Log if it is less than 32. Otherwise, there will always be 32 events in the SOE Log.

5.2 SOE Log

The SOE Log Pointer points to the register address within the SOE Log where the next event will be stored. The following formula is used to determine the register address of the most recent SOE event referenced by the SOE Log Pointer value:

$$\text{Register Address} = 10000 + \text{Modulo}(\text{SOE Log Pointer}-1/32)*8$$

Register	Property	Description	Format
10000~10007	RO	Event 1	See
10008~10015	RO	Event 2	Table 5-3 SOE Log

10016~10023	RO	Event 3	Data Structure
10024~10031	RO	Event 4	
10032~10039	RO	Event 5	
10040~10047	RO	Event 6	
10048~10055	RO	Event 7	
10056~10063	RO	Event 8	
10064~10071	RO	Event 9	
10072~10079	RO	Event 10	
10080~10087	RO	Event 11	
10088~10095	RO	Event 12	
...		...	
10248~10255	RO	Event 32	

Table 5-2 SOE Log

Notes:

1) SOE LOG Data Structure

Offset	Property	Description	Unit
+0	RO	High-order Byte: Event Classification ²	-
	RO	Low-order Byte: Sub-Classification ²	-
+1	RO	Record Time: Year	0-99 (Year-2000)
	RO	Record Time: Month	1 to 12
+2	RO	Record Time: Day	1 to 31
	RO	Record Time: Hour	0 to 23
+3	RO	Record Time: Minute	0 to 59
	RO	Record Time: Second	0 to 59
+4	RO	Record Time: Millisecond	0 to 999
+5	RO	High-order Byte: Reserved	-
	RO	Low-order Byte: Status ²	-
+6 to +7	RO	Event Value ²	-

Table 5-3 SOE LOG Data Structure

2) SOE Event Classification

Event Classification	Sub-Classification	Status	Event Value	Description
1= DI Change	1	1 / 0	1/0	DI1 Inactive / DI1 Active
	2	1 / 0	1/0	DI2 Inactive / DI2 Active
4 = Self-diagnosis	1	None	None	System Parameter Fault
	2			Interval Parameter Fault
5=Operations	1	None	None	Reserved
	2			Power Off
	3			Set Clock via Front Panel
	4			System Parameter Changes via Front Panel
	5			Internal Parameter Changes via Front Panel
	6			Comm. Parameter Changes via Front panel
	7			Preset kWh via Front Panel
	8			Clear SOE via Front Panel
	9			Clear Energy Registers via Front Panel
	10			Clear All Records (SOE Log and Energy Registers) via Front Panel
	11			System Parameters Changes via Communications
	12			Internal Parameter Changes via Communications
	13			Comm. Parameter Changes via Communications
	14			Preset kWh via Communications
	15			Clear SOE via Communications
16	Clear Energy Registers via Communications			
17	Clear All Records (SOE Log and Energy Registers) via Communications			

Table 5-4 SOE Event Classification

5.3 Device Setup

5.3.1 Basic Setup Parameters

Register	Property	Description	Format	Range/Default*
6000	RW	Un	UINT16	1 to 1,000V, 750V*
6001	RW	I Primary	UINT16	1 to 10,000A, 100A*
6002	RW	Shunt Output	UINT16	1 to 100mV, 75mV*
6003~6029	RW	Reserved	UINT16	
6030	RW	Backlight Time-Out	UINT16	0 to 60min, 3min*

Table5-5 Setup Parameters

5.3.2 I/O Setup Parameters

Register	Property	Description	Format	Range/Default*
6220	RW	DI1 Debounce	UINT16	1 to 9999ms, 20*
6221	RW	DI2 Debounce	UINT16	1 to 9999ms, 20*

Table 5-6 I/O Setup

5.3.3 Energy Pulse Setup Parameter

Register	Property	Description	Format	Range/Default*
6400	RW	Energy Pulse Output Enable	UINT16	0= Disabled, 1= Enabled*
6401	RW	Energy Pulse Constant	UINT16	0=25 imp/kWh 1=100 imp/kWh* 2=400 imp/kWh 3=1000 imp/kWh 4=3200 imp/kWh

Table 5-7 Energy Pulse Setup Parameter

5.3.4 Communication Setup Parameters

Register	Property	Description	Format	Range/Default*
6500	RW	Reserved		
6501	RW	Unit ID	UINT16	1 to 247, 100*
6502	RW	Baud Rate	UINT16	0=1200, 1=2400, 2=4800 3=9600*, 4=19200
6503	RW	Comm. Config.	UINT16	0=8N2, 1=8O1, 2=8E1* 3=8N1, 4=8O2, 5=8E2

Table 5-8 Communication Setup

5.4 Time

There are two sets of Time registers supported by the PMC-D721MD – Year / Month / Day / Hour / Minute / Second (Register # 60000 to 60002) and UNIX Time (Register # 60004). When sending time to the PMC-D721MD over Modbus communications, care should be taken to only write one of the two Time register sets. All registers within a Time register set must be written in a single transaction. If registers 60000 to 60004 are being written to at the same time, both Time register sets will be updated to reflect the new time specified in the UNIX Time register set (60004) and the time specified in registers 60000-60002 will be ignored. Writing to the Millisecond register (60003) is optional during a Time Set operation. When broadcasting time, the function code must be set to 0x10 (Pre-set Multiple Registers). Incorrect date or time values will be rejected by the meter. In addition, attempting to write a Time value less than Jan 1, 2000 00:00:00 will be rejected.

Register	Property	Description	Format	Note
60000	9000	High-order Byte: Year	UINT16	0-37 (Year-2000)
		Low-order Byte: Month		1 to 12
60001	9001	High-order Byte: Day	UINT16	1 to 31
		Low-order Byte: Hour		0 to 23
60002	9002	High-order Byte: Minute	UINT16	0 to 59

			Low-order Byte: Second		0 to 59
60003	9003	RW	Millisecond	UINT16	0 to 999
60004 ~ 60005	9004 ~ 9005	RW	UNIX Time	UINT32	0x386D4380 to 0x7FE8177F The corresponding time is 2000.01.01 00:00:00 to 2037.12.31 23:59:59 (GMT 0:00 Time Zone)

Table 5-9 Time Registers

5.5 Clear Control

Register	Property	Description	Format	Note
9600	WO	Clear SOE	UINT16	Writing "0xFF00" to this register to clear SOE Logs.
9601	WO	Clear Energy	UINT16	Writing "0xFF00" to this register to clear Energy Registers (0040~0042)
9602~9609	WO	Reserved	UINT16	
9610	WO	Clear all Records	UINT16	Writing "0xFF00" to this register to clear SOE Logs and Energy Registers.

Table 5-10 Clear Control

5.6 Meter Information

Register	Property	Description	Format	Note
9800 ~ 9819	RO	Meter model ¹	UINT16	See Note 1
9820	RO	Firmware Version	UINT16	e.g. 10000 shows the version is V1.00.00
9821	RO	Protocol Version	UINT16	e.g. 10 means V1.0
9822	RO	Firmware Update Date: Year-2000	UINT16	e.g. 140110 means January 10, 2014
9823	RO	Firmware Update Date: Month	UINT16	
9824	RO	Firmware Update Date: Day	UINT16	
9825	RO	Serial Number	UINT32	e.g. 1701030100 means the 100 th device that was manufactured on January 3 rd , 2017
9827 ~ 9828	RO	Reserved	UINT16	
9829	RO	Feature Number	Bitmap	B7B6B5: 000: None 001: 2DIs + 2Pulse Outputs B4B3: 00: Shunt Input Others: Reserved B2B1B0: 000: 0 to 1000V Others: Reserved

Table 5-11 Meter Information

Notes:

- 1) The Meter Model appears from registers 9800-9819 and contains the ASCII encoding of the string "PMC-D721MD" as shown in the following table.

Register	Value(Hex)	ASCII
9800	0x50	P
9801	0x4D	M
9802	0x43	C
9803	0x2D	-
9804	0x44	D
9805	0x37	7
9806	0x32	2

9807	0x31	1
9808	0x4D	M
9809	0x44	D
9810~9819	0x20	Null

Table 5-12 ASCII Encoding of "PMC-D721MD"

Appendix A Technical Specifications

DC Inputs	
Voltage Input	
Standard	1000V DC
Range	1% to 100% Un
Overload	1.2xUn continuous, 2xUn for 1s
Current Input (via Shunt Resistor)	
Nominal Input (In)	100mV
Nominal Current	100A / 200A / 300A / 400A / 500A / 600A
Starting Current	0.2% of In
Overload	1.2xIn continuous, 10xIn for 10s, 20xIn for 1s
Power Supply (L/+, N/-, GND)	
Standard	95-250VAC/DC, ±10%, 47-440Hz
Burden	<2W
Optional Digital Inputs	
Type	Dry contact, 24VDC internally wetted
Hysteresis	20ms minimum
Energy Pulse Output	
Type	LED / Solid State Relay
Pulse Constant	25 / 100 / 400 / 1000 / 3200 Imp/kWh
Pulse Width	80ms±20ms
Communications	
RS-485	Modbus RTU
Baudrate	1200 / 2400 / 4800 / 9600 / 19200bps
Environmental Conditions	
Operating Temp.	-25°C to 70°C
Storage Temp.	-40°C to 85°C
Humidity	5% to 95% non-condensing
Atmospheric Pressure	70 kPa to 106 kPa
Mechanical Characteristics	
Panel Cutout	68x68 mm
Unit Dimensions	72x72x71.8 mm
IP Rating	52
Shipping Weight	TBD
Shipping Dimensions	TBD

Accuracy

Parameters	Accuracy	Resolution
Voltage	±0.2%	0.1V
Current	±0.2%	0.01A
kW	±0.2%	0.001kW
kWh	IEC 62053-22:2003 Class 0.5	0.1kWh

Appendix B Standards Compliance

Safety Requirements		
CE LVD 2014 / 35 / EU		EN 61010-1: 2010, EN 61010-2-030: 2010
Insulation		IEC 60255-5-2000
Dielectric test:		2kV @ 1 minute
Insulation resistance:		>40MΩ
Impulse voltage:		6kV, 1.2/50μs
Electromagnetic Compatibility CE EMC Directive 2004 / 108 / EC (EN 61326: 2006)		
Immunity Tests		
Electrostatic discharge		EN 61000-4-2:2009
Radiated fields		EN 1000-4-3:2006+A1:2008+A2:2010
Fast transients		EN 61000-4-4:2012
Surges		EN 61000-4-5:2006
Conducted disturbances		EN 61000-4-6:2009
Magnetic fields		EN 61000-4-11:2004
Oscillatory waves		EN 61000-4-2:2009
Emission Tests		
Limits and methods of measurement of electromagnetic disturbance characteristics of industrial, scientific and medical (ISM) radio-frequency equipment		EN 55011: 2009 + A1: 2010 (CISPR 11)
Limits and methods of measurement of radio disturbance characteristics of information technology equipment		EN 55022: 2010 (CISPR 22)
Limits for harmonic current emissions for equipment with rated current ≤16 A		EN 61000-3-2: 2006+A1: 2009 +A2: 2009
Limitation of voltage fluctuations and flicker in low-voltage supply systems for equipment with rated current ≤16 A		EN 61000-3-3: 2008
Emission standard for residential, commercial and light-industrial environments		EN 61000-6-4: 2007+A1: 2011
Electromagnetic emission tests for measuring relays and protection Equipment		EN 61000-4-12: 2006
Mechanical Tests		
Vibration Test	Response	IEC 255-2-1:1989 Level I
	Endurance	IEC 255-2-1:1989 Level I
Shock Test	Response	IEC 255-2-2: 1989 Level I
	Endurance	IEC 255-2-2: 1989 Level I
Bump Test		IEC 255-2-2: 1989 Level I

Appendix C Ordering Guide

		CET Electric Technology		<i>Version 20170222</i>					
Product Code			Description						
PMC-D721MD DC Multifunction Meter									
Display Screen									
L			LCD						
Input Current									
1			0-100mV (via Shunt Output)						
Input Voltage									
1			0-1000V						
Power Supply									
2			95-250V AC/DC , 47-440Hz						
I/O									
X			None						
A*			2xDI+2xPulse Output						
Communications									
A			1xRS-485 Port						
Display Language									
E			English						
PMC-D721MD	-	L	1	1	2	X	A	E	PMC-D721MD-L112XAE (Standard Model)

* Additional charges apply

Contact us

CET Inc.

8/F, Westside, Building 201, Terra Industrial & Trade park, Che Gong Miao, Shenzhen, Guangdong,
P.R.China 518040

Tel: +86.755.8341.5187

Fax: +86.755.8341.0291

Email: support@cet-global.com

Web: www.cet-global.com